

SaguaroX

INSTRUCTION HANDBOOK

SaguaroX M | SaguaroX S | SaguaroX M Heavy

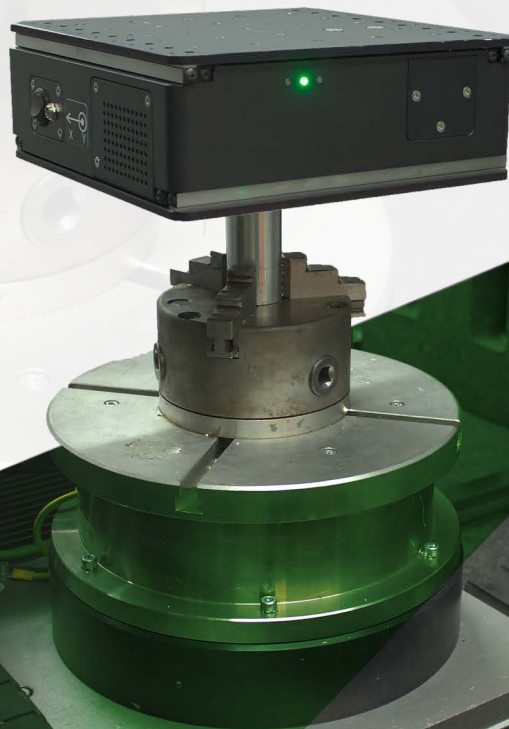

CACTUX

Instruction handbook for SaguaroX | Version 3.0.e | Issue date 2022

Contents

1. Introduction to this Instruction Handbook	6
1.1. How to read and apply the Instruction Handbook	6
1.2. Safety Symbols	6
2. Declaration of Conformity SaguaroX M	7
3. Device Overview SaguaroX M	8
3.1. Intended Use	8
3.2. Device Specification	8
3.3. Graphical Descriptions	8
4. Device Overview SaguaroX S	9
4.1. Intended Use	9
4.2. Device Specification	9
4.3. Graphical Descriptions	9
5. Device Overview SaguaroX M Heavy	10
5.1. Intended Use	10
5.2. Device Specification	10
5.3. Graphical Descriptions	10
6. Package Content SaguaroX M	11
6.1. Contents of the Standard Package	11
6.2. Contents of the Economy Package	11
6.3. Optional Accessories	11
7. Package Content SaguaroX S	12
7.1. Contents of the Standard Package	12
7.2. Optional Accessories	12
8. Package Content SaguaroX M Heavy	13
8.1. Contents of the Standard Package	13
8.2. Optional Accessories	13
8.3. Device, its equipment, and Optional Accessories Description	14
9. Safety	17
9.1. General Warning	17
9.2. Requirements for Operator	17
9.3. Safety Instructions	17
9.4. Hazards	18
10. Disposal	18
11. Transportation, Handling and Storage	19
11.1. Transportation and Storage	19
11.2. Handling	19
12. Installation and Commissioning	20
12.1. Installation of the Device to the CT Machine	20
12.2. Software Installation	21



12.3. Commissioning.....	21
13. Operation.....	22
13.1. Operation Environment.....	22
13.2. Operation Modes - Diodes.....	22
13.3. Operation Instructions.....	22
13.4. Sample Placement.....	23
13.5. Charging of the Device.....	24
14. Inspection, Testing and Maintenance.....	25
14.1. Cleaning of the Device.....	25
14.2. Troubleshooting and Repair.....	25
15. List of used Abbreviations.....	26
16. Glossary.....	26
17. About CactuX s.r.o.	26
18. Contact	26

**IMPORTANT
READ BEFORE USE
SAVE FOR FUTURE REFERENCE**

1. Introduction to this Instruction Handbook

The purpose of the instruction handbook is to provide the user with information that is necessary to use effectively and safely the product during its life cycle.

The instruction handbook consists of the technical data, data and instructions for the product's installation and transport. It also contains information concerning the operation and commissioning of the product.

The user of the product should read the entire instruction handbook. It contains important information on work safety, especially during the operation of this product, which largely depends on its proper use.

- If you do not understand some of the information in the instruction handbook, contact the product manufacturer.
- The instruction handbook can be found at www.cactux.cz/instruction-handbooks.

1.1. How to read and apply the Instruction Handbook



These instructions are marked in the operating instructions with the following safety alert symbols:

- R** CAUTION RISK OF HEALTH OR DAMAGE TO USER,
- !** VERY IMPORTANT INFORMATION FOR THE USER,
- i** GENERAL IMPORTANT INFORMATION FOR THE USER.





Type of instruction handbook: user guide.

1.2. Safety Symbols

The main risks are addressed by the safety pictograms on the Device and the warnings in the operating instructions.

	Name: Warning crushing of hands (Ref. number: ISO 7010-W024) Description: There is a risk of deformation of the hands from mechanical parts of the Device.
	Name: Not to be serviced by users (Ref. number: ISO 7010-P069): Description: There is a risk of injury due to dangers that users do not recognize.
	Name: Refer to instruction manual/booklet (Ref. number: ISO 7010-M002) Description: The user is obliged to start work and / or operation of the Device only after reading the instructions for use.

Other important risks are addressed by the safety pictograms in this instructions handbook.

	Name: Do not extinguish with water (Ref. number: ISO 7010-P011) Description: To prohibit using water to extinguish a fire.
	Name: No open flame; Fire, open ignition source and smoking prohibited (Ref. number: ISO 7010-P003) Description: To prohibit smoking and all forms of open flame.
	Name: Disconnect mains plug from electrical outlet (Ref. number: ISO 7010-M006) Description: The mains plug must be disconnected from electrical outlet for the purposes of maintenance of el. equipment, in the case of malfunction or when left unattended.
	Name: General warning sign (Ref. number: ISO 7010-W001) Description: To signify a general warning

2. Declaration of Conformity SaguarioX

issued in accordance with the meaning of Article 5 (1) (a) (e) and Annex II, Part 1, Section A to Directive 2006/42/EC of the European Parliament and of the Council

Producer: CactuX s.r.o.
Address: Jundrovská 1230/19, Komín, 624 00 Brno
VAT ID (IČ): 09001468

hereby declares on his sole responsibility that the product:

Device identification: SaguarioX
Type/mark: M, S, M Heavy

is in conformity with the provisions of the following European Directives:

Directive 2015/863/EU	RoHS	ref. OJ L 137, 4.6.2015, p. 10-12
Directive 2014/30/EU	EMC	ref. OJ L 96, 29.3.2014, p. 79-106
Directive 2006/42/EU	MD	ref. OJ L 157, 9.6.2006, p. 24-86
Directive 2014/53/EU	RADIO	ref. OJ L 153, 22.5.2014, p. 62-106

Harmonised standards and other technical specifications used in determining compliance:

- EN ISO 12100:2010 - Safety of machinery - General principles for design - Risk assessment and risk reduction
- IEC 60204-1:2018 - Safety of machinery - Electrical equipment of machines - Part 1 General requirements
- IEC 62133-2:2017 - Secondary cells and batteries containing alkaline or other non-acid electrolytes - Safety requirements for portable sealed secondary lithium cells, and for batteries made from them, for use in portable applications - Part 2: Lithium systems
- EN IEC 55014-1:2021 - Electromagnetic compatibility - Requirements for household appliances, electric tools and similar apparatus - Part 1: Emission
- EN IEC 55014-2:2021 - Electromagnetic compatibility - Requirements for household appliances, electric tools and similar apparatus - Part 2: Immunity - Product family standard
- EN IEC 61000-3-2:2019 - Electromagnetic compatibility (EMC) - Part 3-2: Limits - Limits for harmonic current emissions (equipment input current ≤ 16 A per phase)
- EN 61000-3-3:2013 - Electromagnetic compatibility (EMC) - Part 3-3: Limits - Limitation of voltage changes, voltage fluctuations and flicker in public low-voltage supply systems, for equipment with rated current ≤ 16 A per phase and not subject to conditional connection
- EN IEC 61000-6-3:2021 - Electromagnetic compatibility (EMC) - Part 6-3: Generic standards - Emission standard for equipment in residential environments
- EN IEC 62368-1:2020 Audio/video, information and communication technology equipment - Part 1: Safety requirements
- EN 62479:2010 - Assessment of the compliance of low-power electronic and electrical equipment with the basic restrictions related to human exposure to electromagnetic fields (10 MHz to 300 GHz)
- ETSI EN 301 489-17 V3.2.4 (2020-09) - ElectroMagnetic Compatibility (EMC) standard for radio equipment and services; Part 17: Specific conditions for Broadband Data Transmission Systems; Harmonised Standard for ElectroMagnetic compatibility
- ETSI EN 301 489-1 V2.2.3 (2019-11) - ElectroMagnetic Compatibility (EMC) standard for radio equipment and services; Part 1: Common technical requirements; Harmonised Standard for ElectroMagnetic compatibility
- ETSI EN 300 328 V2.2.2 (2019-07) - Wideband transmission systems; Data transmission equipment operating in the 2,4 GHz ISM band; Harmonised Standard for access to radio spectrum

The product meets basic safety requirements for electrical equipment according to the above documents.

The manufacturer has taken measures to ensure continued compliance with the technical documentation and the essential requirements to the safety of the above documents.

Under normal conditions and conditions specified by the manufacturer, the product is safe.

In Brno
Date 25. 2. 2022



Ing. Tomáš Zikmund, Ph.D.
Executive manager

3. Device Overview Saguarox M

3.1. Intended Use

The Device is designed for sample mounting and sample centering in respect to the X-ray tube primarily in industrial and laboratory X-ray Computer Tomography (CT) systems.

3.2. Device Specification

x,y axes travel	100 mm × 100 mm
Sample area	220 mm × 220 mm
Maximum load	15 kg
Weight	9 kg
Dimensions	229 mm × 229 mm × 82 mm (w/o adapters)
Device battery	Li-ion (14.6 V/5.54 Ah)
Runtime	Ca. 16 h continuous run (depends on the condition of Device battery)
Input power	50 W
IP Code	IP20
Operation speed	10 mm per second (fast movement)
Characteristics of the power supply	24V/2.5 A with barrel connector (DC Jack) 5.5 x 2.1 mm
RF Power	< 4 mW

3.3. Graphical Descriptions

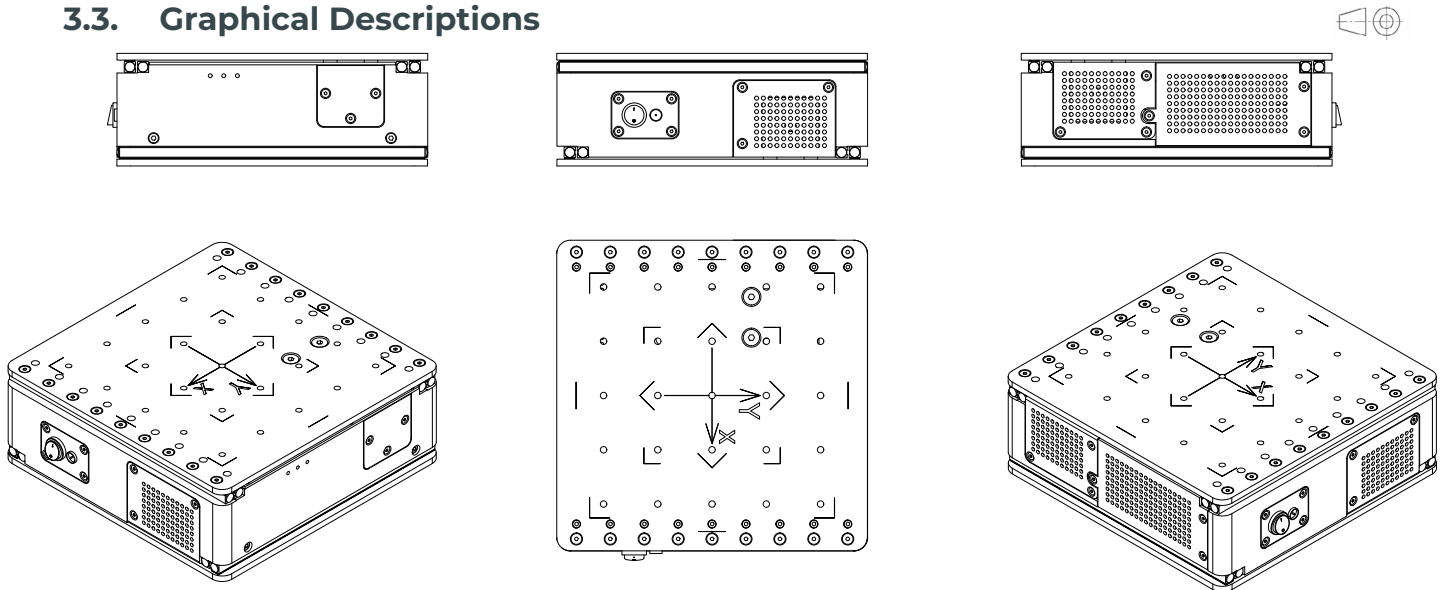

4. Device Overview Saguarox S

4.1. Intended Use

The Device is designed for sample mounting and sample centering in respect to the X-ray tube primarily in industrial and laboratory X-ray Computer Tomography (CT) systems.

4.2. Device Specification

x,y axes travel	50 mm × 50 mm
Sample area	135 mm × 135 mm
Maximum load	7 kg
Weight	4.5 kg
Dimensions	140 mm × 140 mm × 58 mm (w/o adapters)
Device battery	Li-ion (14.4 V/3.4 Ah)
Runtime	Ca. 8 h continuous run (depends on the condition of Device battery)
Input power	50 W
IP Code	IP20
Operation speed	9 mm per second (fast movement)
Characteristics of the power supply	24V/2.5 A with barrel connector (DC Jack) 5.5 x 2.1 mm
RF Power	< 4 mW

4.3. Graphical Descriptions

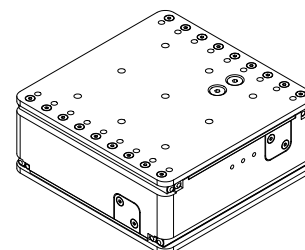
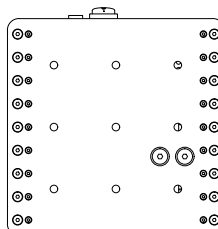
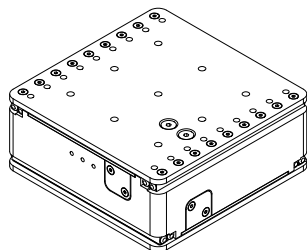
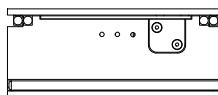
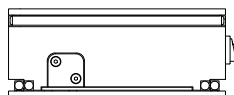

5. Device Overview Saguarox M Heavy

5.1. Intended Use

The Device is designed for sample mounting and sample centering in respect to the X-ray tube primarily in industrial and laboratory X-ray Computer Tomography (CT) systems.

5.2. Device Specification

x,y axes travel	100 mm × 100 mm
Sample area	220 mm × 220 mm
Maximum load	30 kg
Weight	11.5 kg
Dimensions	229 mm × 229 mm × 82 mm (w/o adapters)
Device battery	Li-ion (14.6 V/5.54 Ah)
Runtime	Ca. 16 h continuous run (depends on the condition of Device battery)
Input power	50 W
IP Code	IP20
Operation speed	10 mm per second (fast movement)
Characteristics of the power supply	24V/2.5 A with barrel connector (DC Jack) 5.5 x 2.1 mm
RF Power	< 4 mW

5.3. Graphical Descriptions

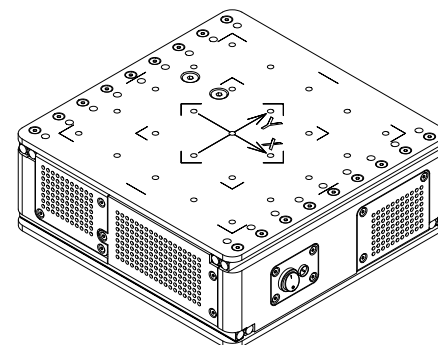
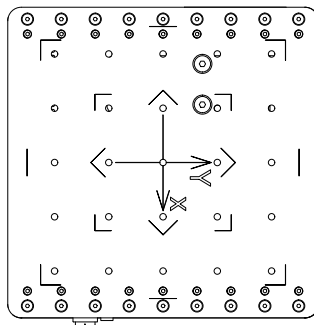
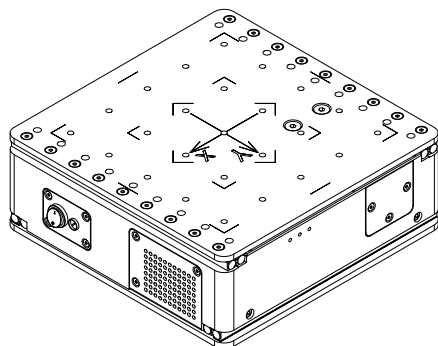
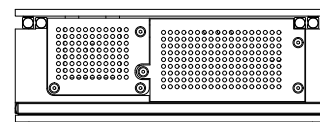
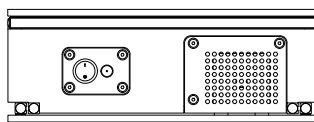
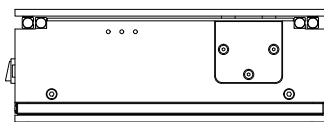

6. Package Content SaguaroX M

The Device and its equipment is delivered in packaging designed for a safe transport. Optional accessories are delivered in a separate package.

6.1. Contents of the Standard Package

Art. no.	Component	Pieces
A0012	SaguaroX M	1 pc.
A0006	Desktop Stand	1 pc.
A0008	Adapter D20	1 pc.
A0009	Adapter D50	1 pc.
A0010	Adapter D150	1 pc.
A0005	Mandrel	1 pc.
S0046	Adapter D20 (Top)	1 pc.
S0064	Transmitter USB Dongle	1 pc.
B0010	Wafer D330	1 pc.
B0049	USB Extension Cable	1 pc.
B0022	Flash Drive	1 pc.
B0023	Power Adapter	1 pc.
B0034	Imbus Key (90 mm)	1 pc.
B0033	Bolt M6×8 ISO 10642	4 pcs.
B0019	Bolt M6×14 AN 9084	4 pcs.
B0019-A	Bolt M6×14 ISO 10642	4 pcs.
B0047	Instruction Handbook	1 pc.
Z0001	Arizona Software	1 pc.
B0050	Plastic Case	1 pc.

6.2. Contents of the Economy Package

Art. no.	Component	Pieces
A0012	SaguaroX M	1 pc.
A0006	Desktop Stand	1 pc.
A0005	Mandrel	1 pc.
S0064	Transmitter USB Dongle	1 pc.
B0049	USB Extension Cable	1 pc.
B0022	Flash Drive	1 pc.
B0023	Power Adapter	1 pc.
B0034	Imbus Key (90 mm)	1 pc.
B0019-A	Bolt M6×14 ISO 10642	4 pcs.
B0047	Instruction Handbook	1 pc.
Z0001	Arizona Software	1 pc.

6.3. Optional Accessories

Art. no.	Component	Pieces
A0011	Joystick	1 pc.
S0080	Folding Aluminum Hand Truck	1 pc.
-	Magnetic Adapters	-
XS0034	Rod Holder (1 - 10 mm)	1 pc.
-	CT-Igel Hedgehogs	-

7. Package Content Saguarox S

The Device and its equipment is delivered in packaging designed for a safe transport. Optional accessories are delivered in a separate package.

7.1. Contents of the Standard Package

Art. no.	Component	Pieces
XS0047	Saguarox S	1 pc.
A0006	Desktop Stand	1 pc.
A0008	Adapter D20	1 pc.
A0009	Adapter D50	1 pc.
XS0034	Rod Holder (1 - 10 mm)	1 pc.
A0005	Mandrel	1 pc.
S0046	Adapter D20 (Top)	1 pc.
S0064	Transmitter USB Dongle	1 pc.
B0049	USB Extension Cable	1 pc.
B0022	Flash Drive	1 pc.
B0023	Power Adapter	1 pc.
B0034	Imbus Key (90 mm)	1 pc.
B0019	Bolt M6×14 AN 9084	4 pcs.
XS0048	Bolt M6×12 ISO 10642	4 pcs.
B0047	Instruction Handbook	1 pc.
Z0001	Arizona Software	1 pc.
B0050	Plastic Case	1 pc.

7.2. Optional Accessories

Art. no.	Component	Pieces
A0011	Joystick	1 pc.
-	Magnetic Adapters	-
XS0034	Rod Holder (1 - 10 mm)	1 pc.
-	CT-Igel Hedgehogs	-

8. Package Content SaguarioX M Heavy

The Device and its equipment is delivered in packaging designed for a safe transport. Optional accessories are delivered in a separate package.

8.1. Contents of the Standard Package

Art. no.	Component	Pieces
XH0001	SaguarioX M Heavy	1 pc.
A0006	Desktop Stand	1 pc.
A0008	Adapter D20	1 pc.
A0009	Adapter D50	1 pc.
A0010	Adapter D150	1 pc.
A0005	Mandrel	1 pc.
S0046	Adapter D20 (Top)	1 pc.
S0064	Transmitter USB Dongle	1 pc.
B0010	Wafer D330	1 pc.
B0049	USB Extension Cable	1 pc.
B0022	Flash Drive	1 pc.
B0023	Power Adapter	1 pc.
B0034	Imbus Key (90 mm)	1 pc.
B0033	Bolt M6×8 ISO 10642	4 pcs.
B0019	Bolt M6×14 AN 9084	4 pcs.
B0019-A	Bolt M6×14 ISO 10642	4 pcs.
B0047	Instruction Handbook	1 pc.
Z0001	Arizona Software	1 pc.
B0050	Plastic Case	1 pc.





8.2. Optional Accessories

Art. no.	Component	Pieces
A0011	Joystick	1 pc.
S0080	Folding Aluminum Hand Truck	1 pc.
-	Magnetic Adapters	-
XS0034	Rod Holder (1 - 10 mm)	1 pc.
-	CT-Igel Hedgehogs	-

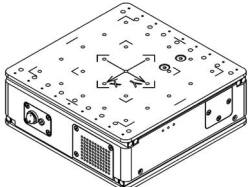
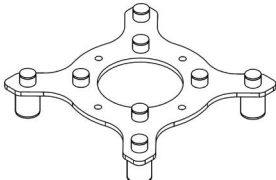
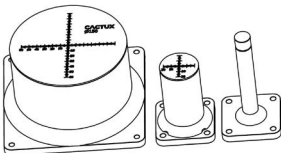
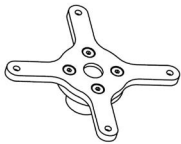
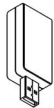
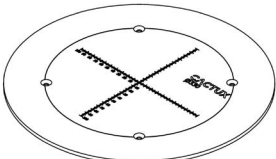
8.3. Device, its equipment, and Optional Accessories Description

Note: The figures in this chapter are not in scale and are placed here for demonstration purposes only.

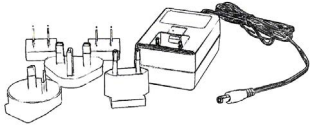
Component	Description	Picture
SaguaroX	<ul style="list-style-type: none"> - is used for centering the sample in respect to the X-ray tube. - Variants are SaguaroX M, SaguaroX S, SaguaroX M Heavy. 	
Desktop Stand	<ul style="list-style-type: none"> - is used to hold the Device, for example during charging of batteries. 	
Adapters	<ul style="list-style-type: none"> - are used for placement of the sample closer to X-ray tube, - three steel-plate equipped Adapters are delivered with different upper diameters (D 150 mm, D 50 mm and D 20 mm). - Adapter D20 is delivered with 1 additional plastic top. 	
Mandrel	<ul style="list-style-type: none"> - is mounted to the Device with Bolt M6x14 ISO 10642, - is used to attach the Device to the chuck inside of the CT shielding cabinet of a CT Device. 	
Transmitter USB Dongle	<ul style="list-style-type: none"> - is connected to the acquisition computer via the appropriate USB port available inside the shielding cabinet of the CT Device or via the provided USB Extension Cable, - provides the communication between Arizona Software and the Device. 	
Wafer D330	<ul style="list-style-type: none"> - is used for the placement of samples that need it according their proportions, - it is used for samples with a weight between 10-15 kg, samples are placed on a marked circle, - should be attached to the Device with Bolt M6x8 ISO 10642. 	

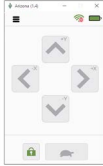
Component	Description	Picture
USB Extension Cable	<ul style="list-style-type: none"> - is used to connect the acquisition computer and Transmitter USB Dongle. 	
Flash Drive	<ul style="list-style-type: none"> - consists of: <ul style="list-style-type: none"> - Instruction Handbook for SaguaroX (this Instruction Handbook), - Driver folder, - Arizona folder. 	
Power Adapter	<ul style="list-style-type: none"> - is used for charging the Device. 	
Imbus Key (90 mm)	<ul style="list-style-type: none"> - is used to install the Bolts. 	
Bolts	<ul style="list-style-type: none"> - are used to attach: <ul style="list-style-type: none"> - Mandrel to the Device with Bolt M6×14 ISO 10642 (SaguaroX M, SaguaroX M Heavy or Bolt M6×12 ISO 10642 (SaguaroX S) - Wafer D330 to the Device when are used for placement of samples that need it according to their proportions with Bolt M6×8 ISO 10642, - Adapter when a firm connection with the Device with Bolt M6×14 AN 9084 is required. 	 <ul style="list-style-type: none"> Bolt M6×8 ISO 10642 Bolt M6×14 AN 9084 Bolt M6×14 ISO 10642 Bolt M6×12 ISO 10642
Arizona Software	<ul style="list-style-type: none"> - is used to control the Device. 	

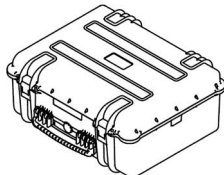
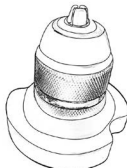
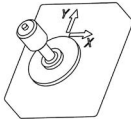
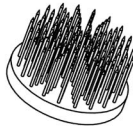
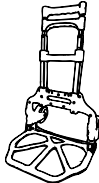
Component	Description	Picture
Plastic Case	<ul style="list-style-type: none"> - is used for transportation and storage of the Device and other content of the package. 	
Rod Holder (1 - 10 mm)	<ul style="list-style-type: none"> - is used to hold cylindrical samples. - It is compatible for cylindrical samples with diameters from 1 to 10 mm. 	
Joystick (optional accessory)	<ul style="list-style-type: none"> - is used for control of the Device, - does not need to be powered by an extra power cable, - is powered via a USB cable connected to the computer. 	
CT-Igel Hedgehogs (optional accessory)	<ul style="list-style-type: none"> - It allows positioning of components in a simple, flexible, fast way, without adhesive materials. - The underside equipped with magnets allows easy positioning on magnetic disks. - Suitable for most foamed materials, such as B. Styrofoam, Styrodur. 	
Folding Aluminum Hand Truck (optional accessory)	<ul style="list-style-type: none"> - Is used for transporting the Device, its equipment and optional accessories in the original packaging. 	

9. Safety

9.1. General Warning

R Follow the safety instructions to avoid the risk of injury to yourself or others around you!

! Any modifications to the product by the user are forbidden and any consequences will not be covered by the support service or product warranties!

! Any arbitrary changes made to this product without the manufacturer's permission release the manufacturer from liability for consequential damage or injury!

i The product might not conform to the European Directives if any part of the supplied product is replaced with a part not supplied by the manufacturer.

9.2. Requirements for Operator



R It is forbidden to work on the Device under the influence of alcohol, drugs or medication, which may reduce the ability to react and pay attention.



! Do not attempt to operate the Device unless you have read all instructions supplied by the manufacturer and understand the procedure!

! Do not exceed any limitations as specified in this instruction handbook.

i The Device may only be operated by a person:

- who is professionally qualified to work with the CT Device in which the Device is installed,
- who is well acquainted with the Device's characteristics and is familiar with the relevant regulations for its operation,
- who follows currently valid regulations concerning occupational safety and accident prevention.

9.3. Safety Instructions

Environmental Conditions

Limits for intended operating environmental conditions	
Location	Indoor use only
Maximum altitude	2,000 m
Temperature range	5 °C to 40 °C
Maximum humidity	80% RH at 31°C



R Do not exceed any limitations of the environmental conditions.



R Operations outside these environmental limits may adversely affect operator safety. For example, if the Device is exposed to extreme temperatures, a battery fire or explosion may result.

! The use of the Device outside the above conditions releases the manufacturer from liability for consequential damage or injury!

! The Device and must not be rinsed with water.

! Protect the Device from moisture, direct sunlight and a dusty environment.

9.4. Hazards

Mechanical Hazards



R There is a risk of injury and deformation of the hand or other part of the body due to the movement of the Device. Take extra care when handling to avoid injuring yourself or others.

R Improper positioning of the Device may damage the Device due to a fall.

R Improper handling of the Device can result in an injury of a person or damage to the Device.

R Do not expose the Device to mechanical shocks.

Electromagnetic Hazards

! The use of the Device can negatively influence electrical controlled medical Devices, such as ICDs and Pacemakers.

i All the equipment must be checked within the signal area of the Transmitter USB Dongle before first switching on a Device. All the equipment which could possibly use the same range of frequency must be switched off.

Thermal Hazards

In connection with the above-mentioned warning and in accordance with the provisions of the relevant law, the user is obliged to prevent fire.



R Do not store flammable liquids or other hazardous substances and gases near the Device.

R No open fire should be used near the Device, do not smoke when operating the Device.

! In case of fire, follow the fire instructions according to the workplace.

i Since the manufacturer does not equip the Device with fire-fighting equipment, the user is obliged to secure the building where the Device is installed:

- Suitable extinguishing media of an approved type, in appropriate quantities, placed at a visible place and protected against damage and misuse.
- Fire extinguishers are subject to regular inspections and the operator must be demonstrably acquainted with their use, as required by applicable law and decree.

Electrical Hazards and Battery Hazards



R Electrical equipment must not be extinguished with water!

! There is a risk of overheating, damage, or explosion of a damaged battery when using the Device improperly. This risk is reduced if no unauthorized manipulation of the Device by the user is performed.

! Damage of a battery may cause a fire, which may cause injury.

i Recommended: powder, snow or halonous fire extinguisher Devices. The operator must be introduced to use them.

10. Disposal

Expected lifetime of the Device is at least 3 years.

Note: Expected lifetime does not apply to the Lion batteries and the provided equipment and optional accessories.

All equipment and optional accessories have a lifespan of at least 1 year, then it is possible to purchase them. For more information, visit our website or contact us at support@cactux.cz.



! The Device is no longer viable if it does not move and / or cannot be charged or / and if the operating time is disproportionately shortened.

! All the equipment included in the package must never be disposed of with general household waste. Observe and comply with the national and federal laws and regulations that are equivalent to EC directives. Once the Device has reached the end of its lifetime, please contact support@cactux.cz about the disposal.

11. Transportation, Handling and Storage

11.1. Transportation and Storage

- i Use the original packaging for transporting the Device, its equipment and accessories.
- i The product should be only stored in the original package provided.
- i It is recommended to store the package in a horizontal position.
- i If the Device is to be shut down for more than two months, it must be:
 - stored in a place that corresponds to limits for intended operating environmental conditions,
 - disconnected from electricity,
 - stored in the original packaging,
 - we recommend to fully charge the Device before its storage.
- i Shutting down the Device for more than 6 months must be consulted with the manufacturer.
- i If the cell is kept for a long time (3 months or more), It is strongly recommended that the cell is preserved at dry and low-temperature.

11.2. Handling

- ! **Avoid damaging the CT Device during handling of the Device.**
- i During handling of the Device inside of the CT cabinet, it must be placed at least 15 cm away from the wall of the cabinet and from the tube and detector of the CT Device.

The Device must be handled safely to prevent harmful impacts.

During handling, the Device:



- must be unplugged from the power source,
- must be turned off.

Device must be handled:

- according to its weight,
- by a physically fit person who can carry at least 15 kg in both hands for at least 1 minute.

Placing of the Device:

- only with the stainless steel plate with engraved x,y coordinate system up.

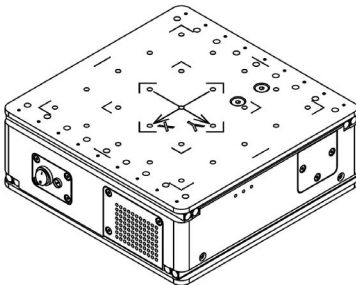

12. Installation and Commissioning

i After unpacking the product, it is recommended to keep the original packaging for later storage or transport.

After unpacking from the protective packaging the Device is ready to be used.

For installation of the Joystick please consult the installation manual attached to this optional accessory.

12.1. Installation of the Device to the CT Machine

If the rotation stage of your CT system is equipped with a chuck, then follow steps 1 and 2. In other cases please contact support@cactux.cz for further instructions if needed.

1. Insert the Device with the attached Mandrel into the CT machine chuck (Mandrel should face down, in the direction of the CT's chuck).
2. Fasten the chuck of your CT.
3. For the installation of the Device, a free USB port inside the shielding cabinet and within the range of the Device is needed.
4. This port is connected to the computer where the Device control software (Arizona) will be installed. Preferably, this computer should be the acquisition computer of the CT Device.
5. If no USB port inside the shielding cabinet is available, or the available USB ports are not in the sight of the Device, the attached USB extension cable should be used.
6. Place the Transmitter USB Dongle inside the shielding cabinet of the CT machine inside the USB port within the range of the Device.

i The Transmitter USB Dongle should be oriented in such a way, that the CactuX sticker is facing towards the Device.

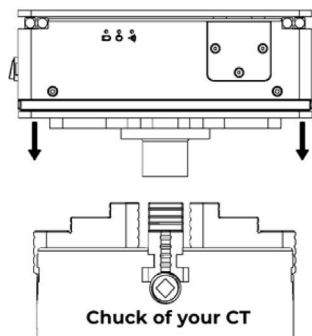

Step 1.

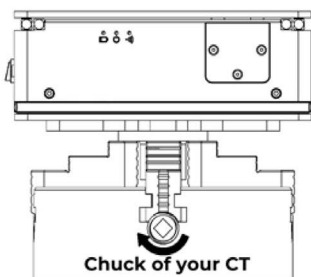

Step 2.

12.2. Software Installation

- Arizona software can only be installed on OS Win 10 and higher.
- The software and configuration file are located on a Flash Drive.
- The latest version of the software can also be found on the webpage www.cactux.cz/arizona-software, whereas the configuration file is only on the Flash Drive since it is unique for each Device.

1. Step

- a. Plug in the Flash Drive to your computer.
- b. Copy folder Arizona to the local folder which has a read/write access (usually Documents).
- c. Disconnect the Flash Drive.

2. Step

- a. Open the Device Manager.
- b. Open Ports (COM and LPT) tab and check which COM port is already being used. In the figure below, a Device is already using - COM4.
- c. If you cannot see the Ports tab in the Device Manager, just continue with the 3rd step.

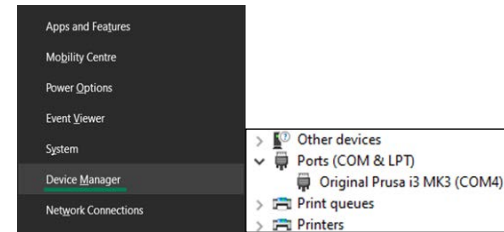

Step 2. b

3. Step

- a. Plug the Transmitter USB Dongle into a free USB port inside of the CT system connected your computer.
- b. Windows should recognize the Transmitter USB Dongle and assign a new COM port number which should appear in the tab. For example COM3 like in the picture 3b.
- c. If you cannot see any new Devices in the Ports tab or you cannot see the Ports tab at all, please contact the CactuX support on support@cactux.cz.

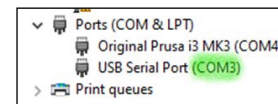

Step 3. b

4. Step

- a. Open Arizona.exe in folder Arizona on your computer.
- b. Press keys Ctrl + S.
- c. Choose the COM port number of your Transmitter USB Dongle into the Serial port box. Then click on Set.
- d. JoyStick port can stay blank when it is not being used.
- e. Close and open Arizona software again.

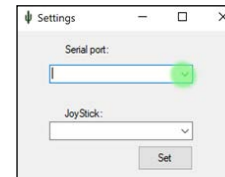

Step 4. d

12.3. Commissioning

Commissioning of the Device

1. After the Device has been installed inside the CT shielding cabinet it is ready to be used.
2. Switch the Device on.
3. In case the diode indicates a low battery, charge the Device (see charging of the Device).

! The Device cannot be operated when it is charging. While the charger is plugged in, movement of the Device is disabled.

4. Open Arizona software on the acquisition computer.
5. The Device receives a signal when the blue diode starts to flash.
6. In case the battery is full and the blue diode does not flash, move the Transmitter USB Dongle closer to the the Device.
7. The Device is now ready to be used.

13. Operation

13.1. Operation Environment

In the shielding cabinet of the CT machine.

R Only operate the Device when the shielding cabinet door is closed in order to prevent injuries to yourself and others.

13.2. Operation Modes - Diodes

Three diodes (blue, green, red) are located on the side of Device.

Blue Diode

Blue diode indicates the signal from the Transmitter USB Dongle.
Diode always flashes when the stage receives the Transmitter USB Dongle signal.

Green Diode

Green diode indicates Device is switched on.

Red Diode

Red diode indicates the status of the battery. In case the charger is not connected and the red diode is flashing, the battery is low and the Device must be connected to the charger. In case the charger is connected, the red diode is on and indicates charging. Red diode turns off when the battery is fully charged.

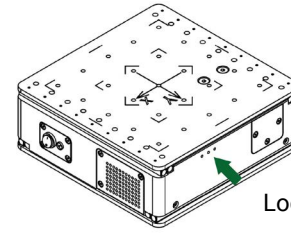

Location of diodes

13.3. Operation Instructions

The operator controls the Device from outside the shielding cabinet using either Arizona or a Joystick (optional accessory).

Instructions to Control Device via Software Arizona

The software displays the positive and negative directions of the axes, which correspond to the symbols on the Device.

The Device can be moved:

- by clicking the screen buttons on Arizona software,
- with keyboard buttons.

Keyboard control:

- keyboard arrows can be used instead of screen buttons,
- control (Ctrl) works the same as the number 5 button,
- spacebar switches speed regimes,
- ctrl + S opens the settings window (where the port name can be set).

Arizona buttons description:

1. about window,
2. signal indicator - shows the strength of connection,
3. battery level indicator,
4. control arrows - move Device,
5. lock button - locks control buttons (arrows and keyboard control),
6. speed switcher - changes regimes between fast and slow.

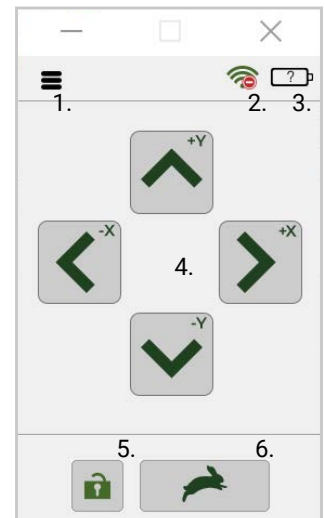

Software environment

The Device communicates when the signal icon is green, and the blue LED flashes.

! Do not use this Device or stop using the Device immediately when:

- it is emitting smoke,
- it is unusually hot to the touch,
- it is emitting any unusual odor,
- it is emitting any unusual noise,
- or it is in any other abnormal state or wear or damage,
- it is no longer safe to use, for example due to aging.

If the problem appears, then switch off the power and if connected, then disconnect the electronics power supply. Contact support@cactux.cz and request repairs.

13.4. Sample Placement

- The samples can be placed directly on the stainless steel plate (with the engraved x,y coordinate system).
- Adapters help to place the sample in a better position relative to the X-ray tube.
- Always pay attention to the weight of the sample and, if the sample is rather heavy, use the appropriate equipment.

R Please note that the sample will rotate during the CT analysis.

R Always place the sample so that its free, 360 degree rotation is enabled.

! Manufacturer is not responsible for any damage to the Device or CT that is associated with improper sample handling.

i Please use the appropriate Adapter for your sample. We recommend not to exceed the upper part of the Adapter by the sample.

Specification for SaguarioX M

Sample with weight < 10 kg

- Samples lighter than 10 kg can be placed directly on the stainless steel plate (with the engraved x,y coordinate system).
- The samples can be placed onto the provided Adapters.

Sample with weight between 10 - 15 kg

- The maximum weight of the load on the Device is 15 kg.
- For a sample heavier than 10 kg, the circular steel plate (wafer D330) must be attached to the Device with four bolts (M6x8 ISO 10642).
- The sample must be placed within the marked circle on the wafer D330.

Sample with weight > 15 kg

R It is forbidden to measure samples heavier than 15 kg using SaguarioX M.

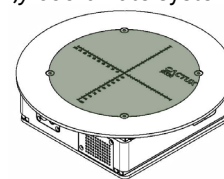

Area for placement of sample with weight between 10 - 15 kg

Specification for SaguarioX S

Sample with weight < 7 kg

- Samples lighter than 7 kg can be placed directly on the stainless steel plate (with the engraved x,y coordinate system).
- The samples can be placed onto the provided Adapters.

Sample with weight > 7 kg

R It is forbidden to measure samples heavier than 7 kg using SaguarioX S.

Specification for SaguarioX M Heavy

Sample with weight < 10 kg

- Samples lighter than 10 kg can be placed directly on the stainless steel plate (with the engraved x,y coordinate system).
- The samples can be placed onto the provided Adapters.

Sample with weight between 10 - 30 kg

- The maximum weight of the load on the Device is 30 kg.
- For a sample heavier than 10 kg, the circular steel plate (wafer D330) must be attached to the Device with four bolts (M6x8 ISO 10642).
- The sample must be placed within the marked circle on the wafer D330.

Sample with weight > 30 kg

R It is forbidden to measure samples heavier than 30 kg using SaguarioX M Heavy.

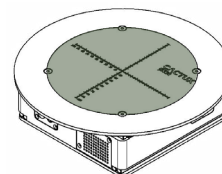

Area for placement of sample with weight between 15 - 30 kg

13.5. Charging of the Device

1. Switch on the Device before charging.
2. Plug the charging connector of the Power Adapter into the power supply connector of the Device.
3. Unplug the charging connector when the battery is fully charged.
4. Proceed to use the Device as specified in the instruction handbook.

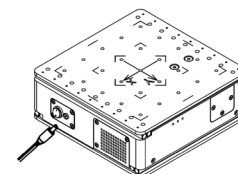

Charging connector

- !** Charging is allowed only using the supplied Power Adapter.
- !** The Device cannot be operated when it is charging. While the Power Adapter is plugged in, movement of the Device is disabled.
- !** Inverse charging should be strictly prohibited. If the cell is connected improperly, it may be damaged.
- i** In case of daily use it is recommended to charge the Device every night.
- i** Continuous charging under appropriate voltage does not cause any loss of characteristics. However, the charge timer is recommended to be installed from a safety consideration, which shuts off further charging at time specified in the product specification.
- i** Over-discharging may cause loss of performance, characteristics, of battery function.
- i** Over-discharging may occur by self-discharge if the battery is left for a very long time without any use.
- i** The cell should be used within a short period after charging because long-term storage may cause loss of capacity by self-discharging.
- i** If long-term storage is necessary, the cell should be stored at lower voltage within a range specified in the product specification, because storage at higher voltage may cause loss of characteristics.

Charging Method	CC-CV (constant voltage with limited current)
Charging Current Standard charge	1,375 mA
Charging Time Standard charge	3 hours
Max. Charge Current	2,750 mA (not for cycle life)
Max. Discharge Current	5,500mAh (continuous discharge) 8,250mAh (not for continuous discharge)
Operating Temperature (Cell Surface Temperature)	Charge : 0 to 45°C, Discharge : -20 to 60°C

- i** The operator is obliged to check the Device, Equipment and accessories before starting work for signs of damage or other properties that could lead to a threat to health or property.
- i** Switch off the Device and disconnect the Power Adapter from the Device before maintenance.
- i** Package includes Power Adapter with interchangeable adapters (USA, EU, UK and AUS).
- i** The Power Adapter is CE/UL/CCC certified.

14. Inspection, Testing and Maintenance

14.1. Cleaning of the Device

Wipe off dirt with a dry, lint-free cloth only.

If the line has been cleaned with a more aggressive substance (eg IPA, ethanol, ...), it is necessary to restore the oil film on the linear line. Use ordinary oil for fine mechanics to restore the oil film on the linear guide.

Keep the Device clean and dry.

i Cleaning of the Device is only performed when the Power Adapter is disconnected from the Device. The Device must be switched off during cleaning.

! Do not use flammable liquids or abrasives to clean the Device.

! Do not clean with pressurized water.

i Labels with instructions for operation, maintenance and identification must be kept legible.

14.2. Troubleshooting and Repair

i The Device stops moving when

- there is too much load on the Device,
- an obstacle prevents the Device from moving,
- battery status is too low (indicator),
- movement is blocked by the software (button in the software),
- the Device loses communication with the Transmitter USB Dongle,
- other reasons occur.

Solution: remove obstacles, charge the battery, unlock the Device, or proceed to the next info.

i If the Device does not move

- First check the speed. In turtle mode, the movement may not be noticeable. Switch to rabbit mode and check the speed of movement. If it does not help and the Device still does not move, move on to the next step.
 - Check the battery status, if the battery is low, charge the Device. If it does not help and the Device still does not move, move on to the next step.
 - Check the communication status:
 - if the blue LED diode on the Device is not flashing,
 - and / or the symbol in Arizona is a stop sign on the wifi symbol.
- If one of the situations occurs then move the Transmitter USB Dongle to a better position in the range of the Device.
- If the LED flashes and at the same time there is no stop sign on the wifi symbol, but the Device is still not moving, restart the Device (switch off / on) and perform the above steps again.
 - If the Device still does not move, contact support@cactux.cz.

i If any liquid has entered the Device then:

- switch off the Device,
- disconnect the power supply cable,
- contact support@cactux.cz and request repairs.

i If the Device has been stored at a low temperature or in an environment of high humidity, it must be allowed to reach ambient conditions before being powered up.

In case of any other defect, contact support@cactux.cz.

15. List of used Abbreviations

CT	X-ray Computed Tomography
μCT	micro-CT
IP Code	Ingress Protection Code
RF	Radio Frequency

16. Glossary

Manufacturer	A company CactuX
Product	All contents of the package including optional accessories
Device	SaguaroX
Operator	An user qualified to operate the Device

17. About CactuX s.r.o.

CactuX s.r.o. is a start-up company developing and producing addons for microCT instruments. Our first product is the translation stage SaguaroX - a new unique motorized sample stage designed specifically for μCT stations. It provides quick and easy sample mounting and motorized movement. CactuX was founded in March 2020 by the researchers from Laboratory of X-ray micro and nano computed tomography at CEITEC Brno University of Technology who have long-term experience with R&D in the computed tomography field.

18. Contact

support@cactux.cz
www.cactux.cz

CactuX s.r.o.
Jundrovská 1230/19, Komín, 624 00 Brno
CRN (IČO): 09001468
VATIN (DIČ) CZ09001468
www.cactux.eu

Contact

✉ support@cactux.cz
🌐 www.cactux.cz

CactuX s.r.o.

Jundrovská 1230/19, Komín, 624 00 Brno

CRN (IČO): 09001468

VATIN (DIČ): CZ09001468

Instruction handbook for SaguarioX

Issue date 2022

Version 3.0.e